



Excellent NIS Optical System

With excellent NIS optical system, NM900 series microscope provides high resolution and chromatic aberration corrected images both in the eyepieces and on the monitor.



NM910

Modular Design

NM900 series has been designed with modularity to meet various industrial and materials science applications. It gives users flexibility to build a system for specific needs.



NM930

Intuitive Microscope Controls

Remote Control Pad

Objectives could be switched by simply pressing the rotating buttons. Users could also self-define two of the most commonly used objectives. User could swap between these two objectives by pressing the green button.



Shortcut Buttons

With this shortcut button, the user could switch 2 preset objectives fast. Also, this shortcut button could be set with other functions by user.



ECO Function

The microscope light would be off automatically after 30 minutes from operators leave. It can not only save energy, but also save the lamp lifetime.



Intuitive Microscope Controls

NIS45 Series Objectives

By using carefully selected high-transparent glass and advanced coating technology, NIS45 objective lens can provide high resolution image and accurately reproduce the natural color of the specimen. For special applications, a variety of objectives is available, including polarizing and long working distance.



Nomarski DIC

With newly designed DIC module, the height difference of a specimen which can not be detected with brightfield becomes a relief-like or 3D image. It is ideal for the observation of LCD conducting particles and the surface scratches of hard-disk etc.



Ergo Tilting Trinocular Head

Eye tube can be adjustable from 0° to 35°, Trinocular tube can be connected to SLR camera and digital camera, having a 3-position beam splitter (0:100, 100:0, 80:20), the splitter bar can be assembled on the either side according to user's requirement.



Focusing system

In order to make the system suitable for the operating habits of the operators, the knob of focusing and stage can be adjusted to the left-hand side or right-hand side. This design makes the operation comfortable.



Various Observation Methods

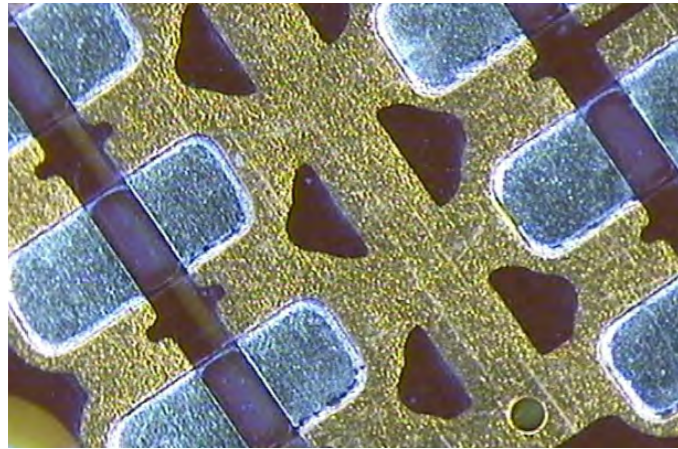

Wafer

Darkfield

Darkfield enables the observation of scattered or diffracted light from the specimen. Anything that is not flat reflects this light while anything that is flat appears dark so imperfections clearly stand out. The user can identify the existence of even a minute scratch or flaw down to the 8nm level-smaller than the resolving power limit of an optical microscope. Darkfield is ideal for detecting minute scratches or flaws on a specimen and examining mirror surface specimens, including wafers.

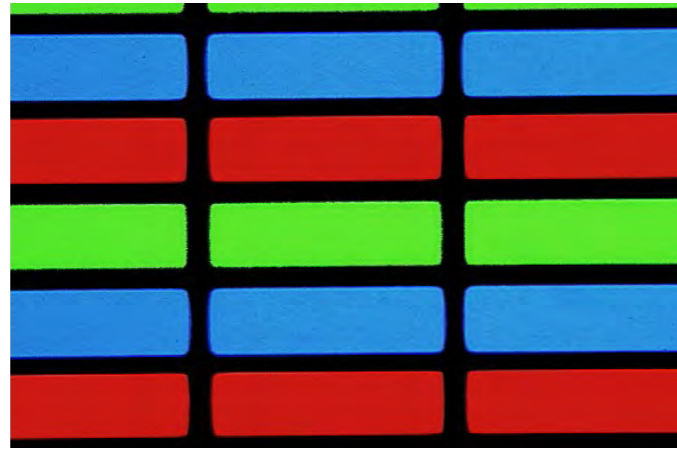

LCD

Transmitted Light Observation

For transparent specimen such as LCDs, plastics, and glass materials, true transmitted light observation is available by using a variety of condensers. Examining specimen in transmitted brightfield and polarized light can be accomplished all in one convenient system.

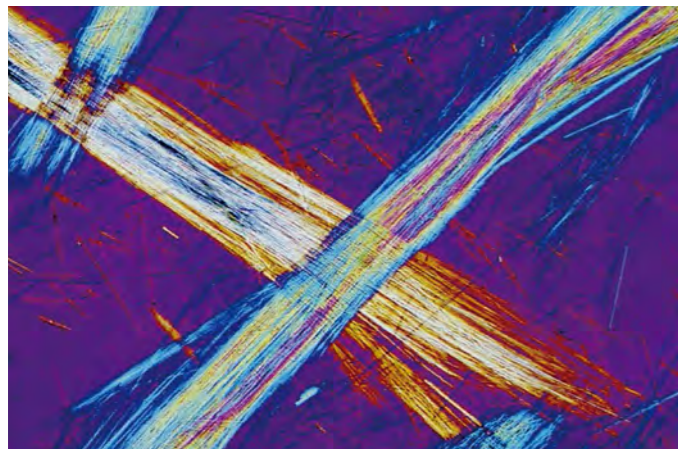

Asbestos

Polarized Light

This microscopic observation technique utilizes polarized light generated by a set of filters (analyzer and polarizer). The characteristics of the sample directly affect the intensity of the light reflected through the system. It is suitable for metallurgical structures (i.e., growth pattern of graphite on nodular casting iron), minerals, LCDs and, semiconductor materials.



Conducting Particles

Differential Interference Contrast

DIC is a microscopic observation technique in which the height difference of a specimen not detectable with brightfield becomes a relief-like or three-dimensional image with improved contrast. This technique utilizes polarized light and can be customized with a choice of three specially designed prisms. It is ideal for examining specimens with very minute height differences, including metallurgical structures, minerals, magnetic heads, hard-disk media, and polished wafer surfaces.

NM910-R/TR

	NM910-R	NM910-TR
Optical System	NIS45 Infinite optical system	
Eyepiece	SW10X/25 SW10X/22 EW12.5X/16 WF15X/16 WF20X/12	
Viewing Head	Ergo tilting trinocular head, adjustable from 0° to 35°, interpupillary distance 47-78mm Seidentopf trinocular head, inclined at 30°, interpupillary distance 47-78mm Seidentopf binocular head, inclined at 30°, interpupillary distance 47-78mm	
Objective	NIS45 Series objective	
Nosepiece	Sextuplet nosepiece	
Condenser	NA0.65	
Illumination	Reflected light 24v/100w halogen lamp, kohler illumination	Reflected light 24v/100w halogen lamp, kohler illumination Transmitted light 24v/100w halogen lamp, kohler illumination, with ND6/ND25 filter
Focusing	Coaxial coarse and fine adjustment, fine division 1 um, moving range 35mm, sample space 76mm	Coaxial coarse and fine adjustment, Fine Division 1 um, moving range 35mm, sample space 56mm
Stage	"4" Stage (right or left handle) Double layer mechanical stage 190X / 152 / 78mmx32m (right or left handle) Double layer mechanical stage 190X / 152 / 78mmx54mm (right or left handle)	
Accessories	Power cord	

NM930-R/TR

	NM930-R	NM930-TR
Optical System	NIS45 Infinite optical system	
Eyepiece	SW10X/25 SW10X/22 EW12.5X/16 WF15X/16 WF20X/12	
Viewing Head	Ergo tilting trinocular head, adjustable from 0° to 35°, interpupillary distance 47-78mm Seidentopf trinocular head, inclined at 30°, interpupillary distance 47-78mm Seidentopf binocular head, inclined at 30°, interpupillary distance 47-78mm	
Video Adapter	0.5 X C-Mount	
Objective	NIS45 Series objective	
Nosepiece	Auto sextuplet nosepiece	
Condenser	NA0.65	
Illumination	Reflected light 12v/100w halogen lamp, kohler illumination	Reflected light 12v/100w halogen lamp, kohler illumination Transmitted light 12v/100w halogen lamp, kohler illumination, with ND6/ND25 filter
Focusing	Coaxial coarse and fine adjustment, fine division 1 um, moving range 35mm, sample space 76mm	Coaxial coarse and fine adjustment, fine division 1 um, moving range 35mm, sample space 56mm
Stage	"4" Stage (right or left handle) Double layer mechanical stage 190X / 152 / 78mmx32m (right or left handle) Double layer mechanical stage 190X / 152 / 78mmx54mm (right or left handle)	
Accessories	Neximage 10.0 Power cord	

NM900 System diagram

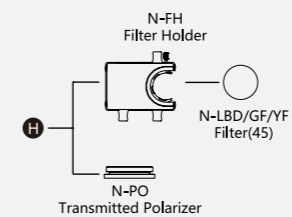
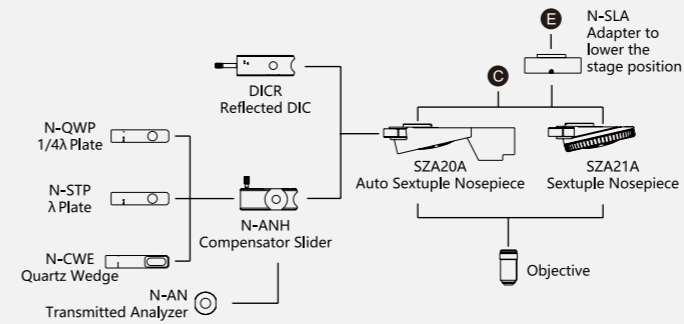
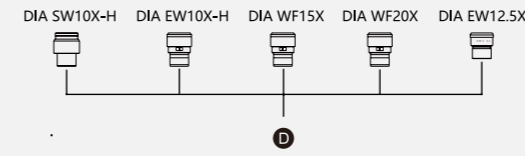
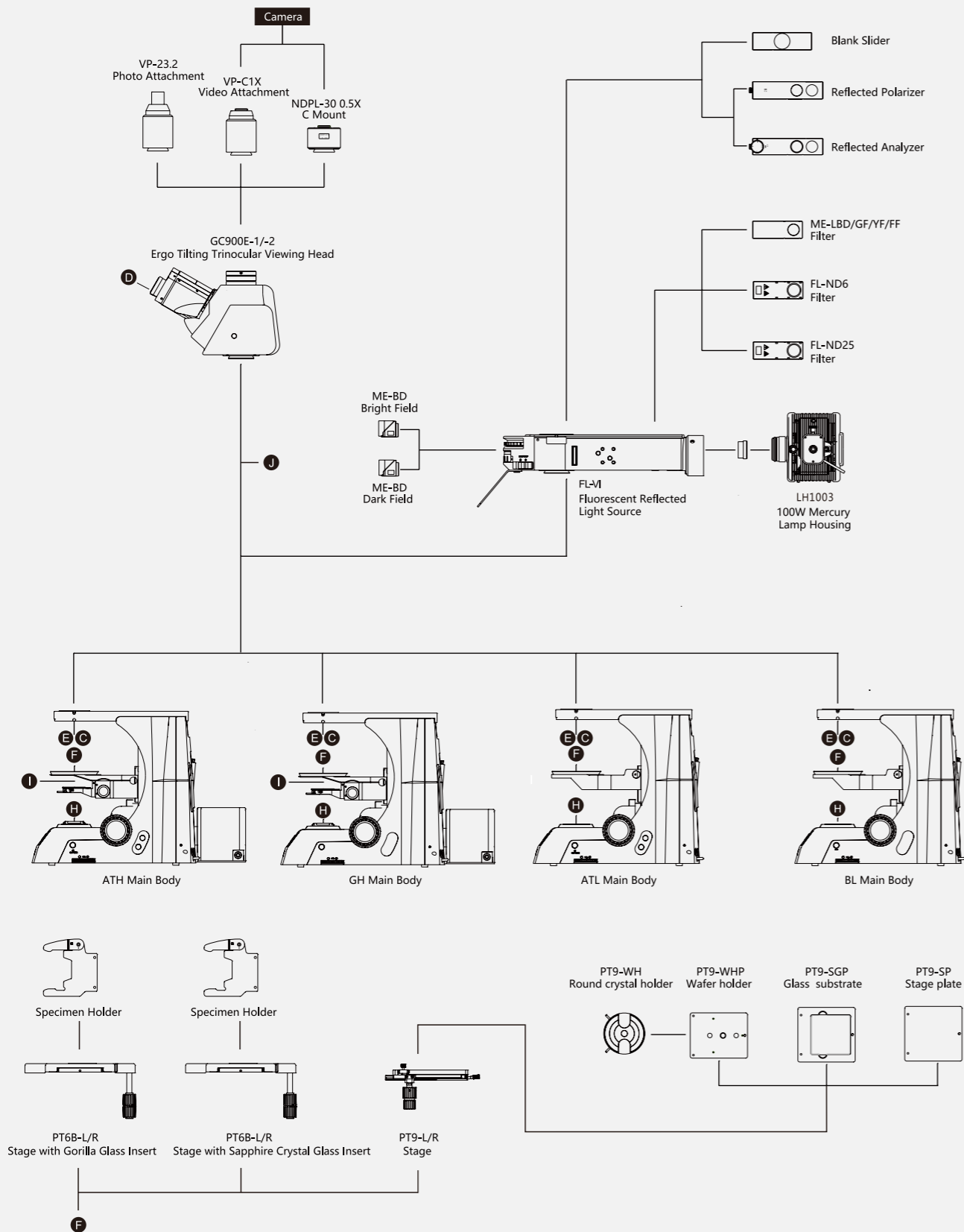

NM910-R Dimension

Unit:mm

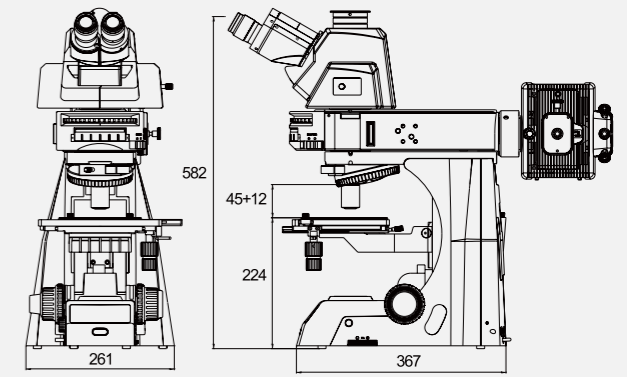

NM930-R Dimension

Unit:mm

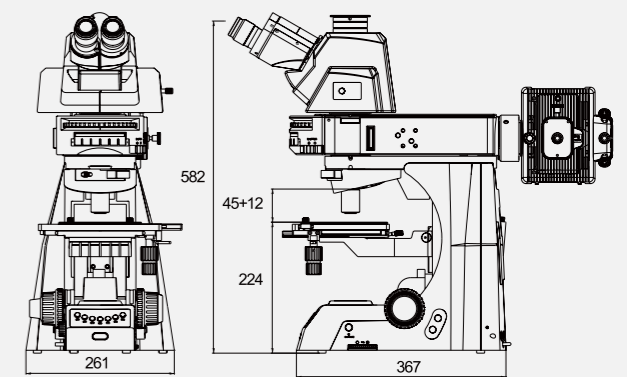

NM910-TR Dimension

Unit:mm

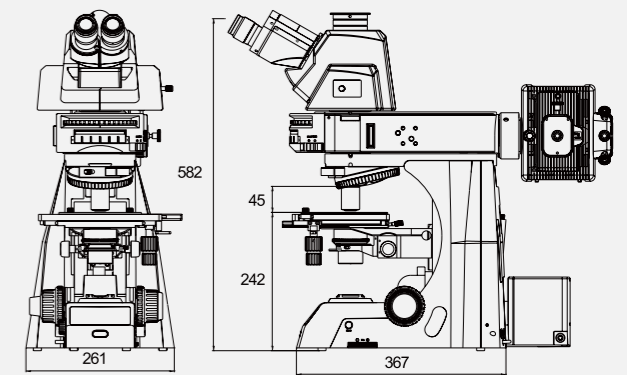

NM930-TR Dimension

Unit:mm

